

L735/805/850-40C32

multi-wavelength LED

◆ Outer dimension (Unit: mm)

L735/805/850-40C32 consists of an AlGaAs (735, 805, 850nm) LED mounted on TO-18 4pins type stem with a glass lens.
Chips are connected as anode common.

◆ Specifications

1) Product Name	Multi-wavelength LED Lamp
2) Type No.	L735/805/850-40C32
3) Chip	
(1) Chip material	AlGaAs
(2) Peak wavelength	735, 805, 850nm
4) Package	
(1) Stem	TO-18 4pin type
(2) Lens	Φ5 spherical glass

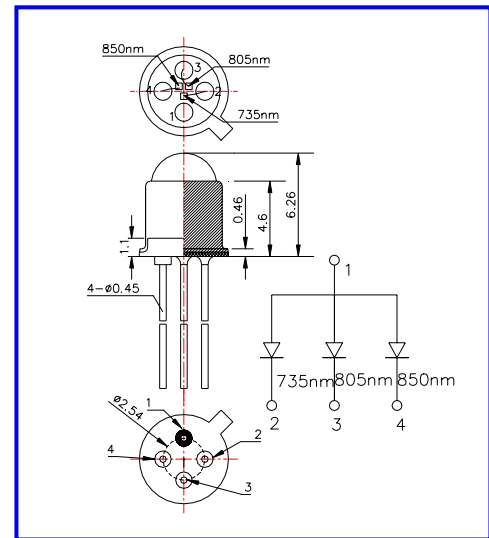

◆ Absolute Maximum Ratings [Ta=25°C]

Item	Symbol	Maximum Rated Value			Unit
		735	805	850	
Power Dissipation	PD	180	170	160	mW
Forward Current	IF	75	100	100	mA
Pulse Forward Current	IF	200	300	500	mA
Reverse Voltage	VR	5			V
Operating Temperature	TOPR	-20 ~ +80			°C
Storage Temperature	TSTG	-30 ~ +100			°C
Soldering Temperature	TSOL	240			°C

‡Soldering condition: Soldering condition must be completed within 3 seconds at 240°C and is allowed in the area apart 3mm from the bottom of the lamp.

◆ Electro-Optical Characteristics [Ta=25°C]

Item	Symbol	Wavelength	Condition	Minimum	Typical	Maximum	Unit
Forward Voltage	VF	735	IF=50mA		1.85	2.30	V
		805					
		850					
Reverse Current	IR		VR=5V			10	u A
Total Output Power	PO	735	IF=50mA	5.0	9.0		mW
		805		5.0	9.0		
		850		5.0	9.0		
Peak Wavelength	λP	735	IF=50mA	710	735	755	nm
		805		790	805	820	
		850		835	850	865	
Half Wavelength	Δλ	735	IF=50mA		40		nm
		805			40		
		850			40		

‡Total Radiated Power is measured by Photodyne #500